

Aug. 26, 1941.

L. HAMMOND ET AL

2,253,782

KEYBOARD FOR ELECTRICAL MUSICAL INSTRUMENTS

Filed May 7, 1940

3 Sheets-Sheet 1

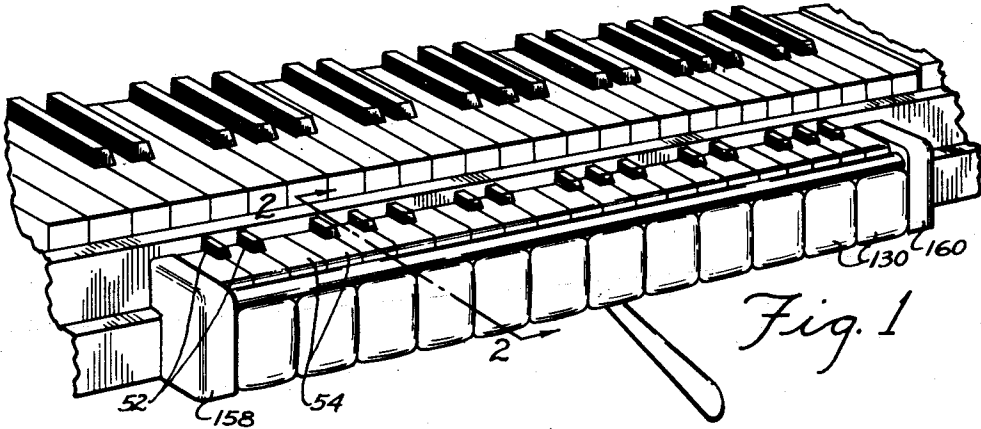

Fig. 1

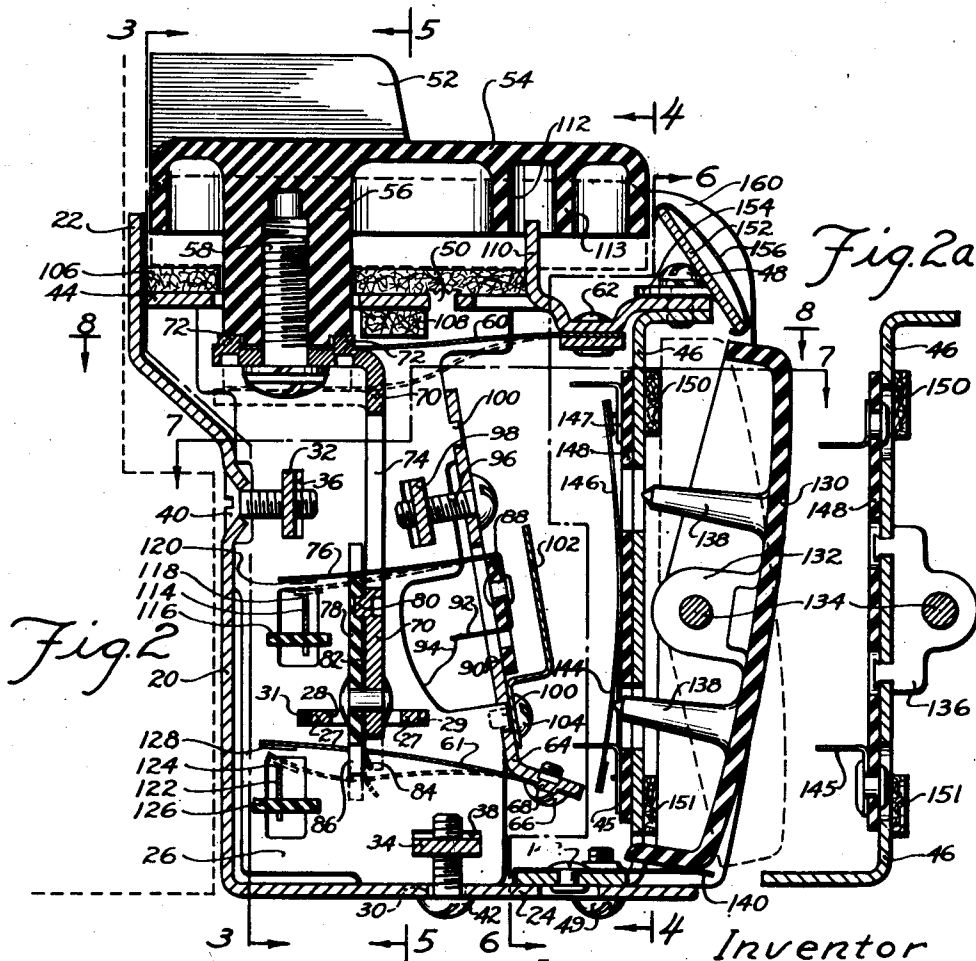

Fig. 2

Fig. 2a

Inventor
 Laurens Hammond
 & George H. Stephens
 B
A. Tucker Atty.

Aug. 26, 1941.

L HAMMOND ET AL

2,253,782

KEYBOARD FOR ELECTRICAL MUSICAL INSTRUMENTS

Filed May 7, 1940

3 Sheets-Sheet 2

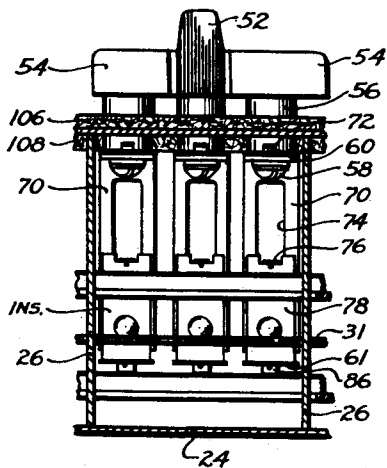

Fig. 3

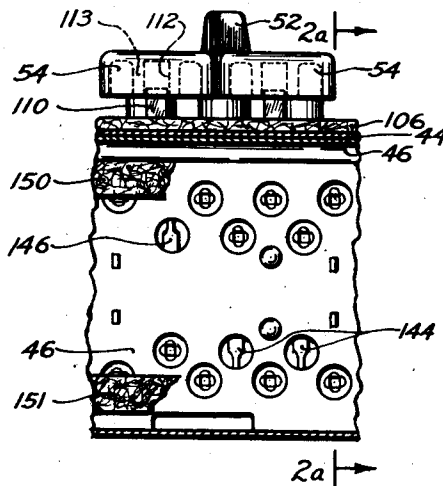

Fig. 4

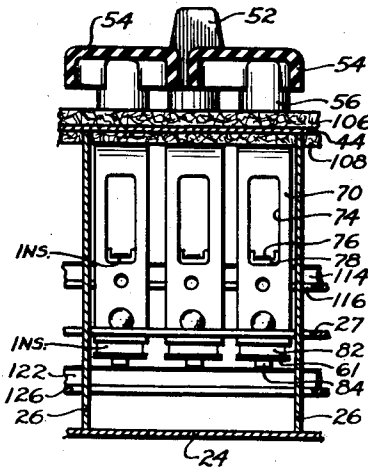

Fig. 5

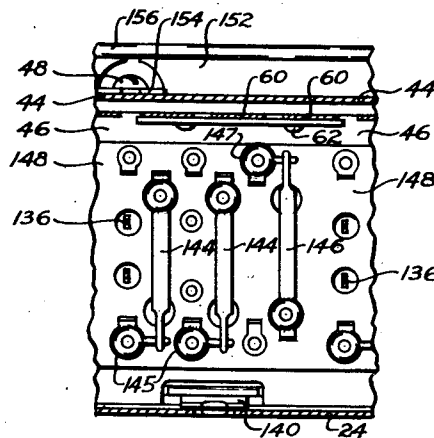

Fig. 6

Inventor
Laurens Hammond
& George H. Stephens
By Benjamin T. Nupper Atty.

Aug. 26, 1941.

L. HAMMOND ET AL

2,253,782

KEYBOARD FOR ELECTRICAL MUSICAL INSTRUMENTS

Filed May 7, 1940

3 Sheets-Sheet 3

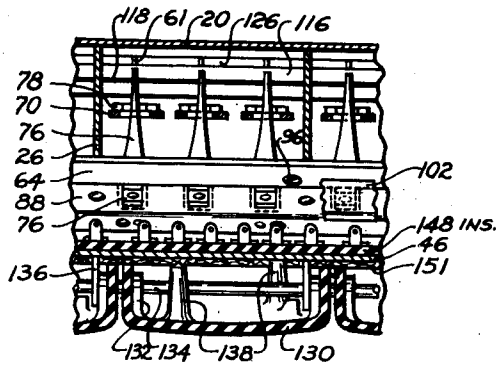

Fig. 7

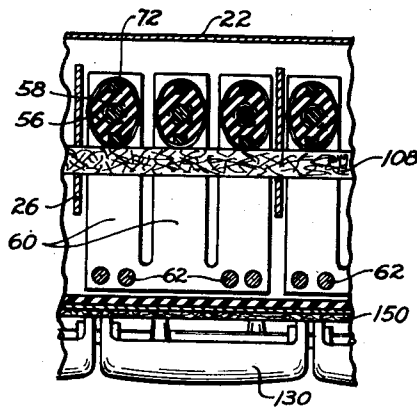

Fig. 8

Inventor
Laurens Hammond
& George H. Stephens
By Benjamin P. Hopper Atty.

UNITED STATES PATENT OFFICE

2,253,782

KEYBOARD FOR ELECTRICAL MUSICAL INSTRUMENTS

Laurens Hammond, Chicago, and George H. Stephens, Glencoe, Ill., assignors to Hammond Instrument Company, Chicago, Ill., a corporation of Delaware

Application May 7, 1940, Serial No. 333,824

13 Claims. (Cl. 84—423)

Our invention relates generally to keyboards for electrical musical instruments, and more particularly to a keyboard of this type which is exceedingly small and compact.

In general, the keyboard comprises a plurality of octaves of keys which are preferably of the same width and spacing as keys of a standard piano, but which are considerably shorter in length so that the keyboard as a whole may be attached to a piano keyboard without interfering with the normal use of the piano.

The general features of construction of this keyboard and its advantages and uses in their broader aspects are disclosed and claimed in the application of Laurens Hammond, Serial No. 322,903, filed March 8, 1940, the present application being directed to constructional features of the keyboard which are more or less independent of the external shape, appearance and uses of the keyboard.

It is thus an object of our invention to provide an improved simple and compact keyboard for an electrical musical instrument in which each of the keys may be utilized reliably to operate one or a plurality of switches, and in which tablet operated switches are incorporated as a structural part of the keyboard.

A further object is to provide a simple keyboard for electrical musical instruments which may be economically manufactured and which will be reliable and durable.

A further object is to provide a keyboard for electrical musical instruments in which the key stroke is very short, the key action rapid, and which may be conveniently used by the musician.

Other objects will appear from the following description, reference being had to the accompanying drawings in which:

Figure 1 is a perspective view of the keyboard of my invention showing it as attached to the front rail of a piano;

Figure 2 is an enlarged transverse sectional view of the keyboard taken on the line 2—2 of Fig. 1;

Figure 2a is an enlarged sectional view of the tablet switch mechanism and tablet mounting taken on the line 2a—2a of Fig. 4; and

Figures 3 to 8 inclusive are longitudinal sectional views taken on the lines 3—3 to 8—8 inclusive, respectively, of Fig. 2.

The keyboard comprises a frame or casing, the back and bottom of which are provided by an angle sheet forming a rear wall 20 having a rearwardly offset upper portion 22, and a horizontal bottom portion 24. The offset in the rear wall

portion of the sheet 20 is provided to make the keyboard more easily attachable to pianos, the front rails of which are often of protruding conformation.

At intervals spaced approximately the space of three keys apart, are vertical frame plates 26 which have ears 30 projecting into complementary shaped slots formed in the bottom wall 24 of the sheet 20. The plates 26 are held in properly spaced relation not only by their ears 30, but also by an apertured bar 27, extending through slots 28 in the plates, and having notches 29 which engage the plates. The notched bar 27 is held in such interlocking engagement with the plates 26 by a wire 31 which is pushed through the slots 28 after the bar 27 has been inserted and moved laterally to cause the notches therein to engage the plates.

The plates 26 are held in assembled relation with the casing sheet 20 by clamping bars 32, 34 which extend through slots 36 and 38 respectively formed in the vertical frame plates 26, and are clamped against the edges of these slots by a plurality of screws 40 and 42 respectively, which are tapped in the bars 32 and 34 and extend through the rear and bottom portions 20 and 24 respectively, of the casing sheet 20.

A top frame plate 44 is secured to a front frame plate 46 by screws 48 as best shown in Fig. 2, the front plate 46 being secured to the bottom 24 of the angle sheet 20 by screws 49. The top plate 44 is staked to the vertical frame plates 26 by lugs 50, which project upwardly from the frame plates 26 through complementary shaped slots in the top plate 44. The upper ends of the frame plates are thus held in properly spaced relation.

The playing keys 52, 54 are preferably made of a molded plastic and of hollow boxlike construction, each having a downwardly projecting boss 56 which is tapped to receive a fastening screw 58. Each of the keys is supported by a pair of leaf springs 60, 61. Several of the leaf springs 60 may be made integral as shown in Fig. 8, and have their forward ends secured by rivets 62 to the top frame plate 44.

Leaf springs 61 may likewise be formed in integral groups of three or more, the groups being secured to a switch arm supporting plate 64 by screws 66, suitable dowels 68 partly punched from the plate 64 being provided accurately to locate the springs 61. The springs 61 also serve as switch arms as will be more fully described hereinafter.

Switch actuators 70 are secured to the keys 52,

54 by screws 58, the actuators having aligning dowels 72 partly punched therefrom to engage in complementary recesses formed in the lower surfaces of the bosses 56. The dowels also project through suitable complementary openings in the leaf springs 60 so as to prevent rotation of the keys about the axis of the screws 58. The actuators 70 are provided with openings 74 through which extend resilient switch arms 76. In each instance, the arm 76 is insulated from its associated actuator 70, by a notched insulating member 78 which is riveted to the lower end of the actuator 70, being further fixed in position by a dowel 80 partially punched from the actuator 70.

A spring latch 82 is clamped between the insulating member 78 and the actuator 70, and has a tip 84 which is bent at an angle but otherwise conforms to the shape of a tip 86 formed at the lower end of the member 78. The tips 84 and 86 project through a suitable opening formed in the leaf spring 61, and the tip 84 thus acts as a latch frictionally to hold the spring 61 in engagement with insulating member 78, in the position shown in Fig. 2.

The switch arms 76 are riveted to an insulating strip 88 and project through suitable openings 90 formed in switch supporting plate 64 so as not to make contact with the latter. Each of the switch arms 76 has a lug 92 formed integrally therewith to which a connecting wire 94 is soldered.

The plate 64 is suitably secured to the vertical frame plates 26 by screws 96 which are threaded in a clamping bar 98 which extends through suitable slots formed in the vertical frame plates 26. The plates 26 are also provided with forwardly extending ears or lugs 100 which engage in complementary slots formed in the frame plate 64 so as to aid in holding the latter in fixed position with respect to the frame plates. The switch arms 76 are suitably shielded by a guard 102 secured to the switch mounting plate 64 by screws 104.

Downward movement of the keys 52, 54 is limited by a down-stop 106 which may be made of felt or similar material, and rests upon the top plate 44. The upward movement of the keys is limited by an up-stop 108 which may be in the form of a strip of felt secured beneath the top plate 44 and adapted to be engaged by the leaf springs 60. The white keys 54 are prevented from being swung sidewardly beyond a predetermined permissible extent by lugs 110 struck upwardly from the top plate 44, which project into suitable recesses 112 which are formed in bosses 113 projecting downwardly from the tops of the keys 54.

Bus bars 114 are secured to insulating strips 116 which are longitudinally slideable, being supported by the vertical frame plates 26. Each of the bus bars 114 is provided with a contact wire 118, which may be welded or soldered to the upper edge of the bus bar, the wire preferably being made of a rare metal alloy of the platinum group. A similar contact wire 120 is welded to the ends of each of the switch arms 76 and is adapted to contact the bus bar contact wire 118 whenever the key associated with the switch arm 76 is depressed, the switch arm being resiliently biased to move to the position to make such contact, that is, the switch arm 76 normally assumes the position in which it is shown in dotted lines in Fig. 2, being flexed to its full line position by the insulating member 78 as the actuator 70

moves upwardly upon the return stroke of the key.

A bus bar 122 having a contact wire 124 welded to its upper edge is supported by and secured to an insulating strip 126 which is mounted for limited longitudinal sliding movement through suitable openings formed in the vertical frame plates 26. The leaf springs 61 are provided with contact wires 128 which, when the associated keys are depressed, engage the contact wire 124, as indicated in dotted lines in Fig. 2. While the insulating strips 116 and 126 extend the full length of the keyboard, there is preferably a separate bus bar such as 114 and 122 for each octave of the keyboard, since in the preferred form of the instrument as shown in the co-pending application of Laurens Hammond and John M. Hanert, Serial No. 293,444, filed September 5, 1939, the electrical circuits to be made require separate bus bars for each octave. Any suitable means may be provided for longitudinally sliding the insulating strips 116 and 126 which support the bus bars, for the purpose of changing the points on their contact wires which the contact wires 120 and 128 will engage. In this way, the portions of the contact wires which are brought into engagement may be changed, should the wires fail to make electrical contact due to the presence of a particle of dust or other foreign matter, or because of localized wear of the contact wires 118, 124. Such shiftable bus bars, and the means for longitudinally shifting them are more fully disclosed in my Patent No. 2,099,204, granted November 16, 1937.

Arranged side by side so as to form the front face of the keyboard assembly are a plurality of tilting tablets 130 which are preferably made of a molded plastic material and of hollow construction, having bosses 132 formed on their inner side walls. The tablets are capable of tilting motion about a shaft 134 extending through the bosses 132, the shaft 134 being supported at intervals by brackets 136 which are peened to the front plate 46 as best shown in Fig. 2a. Each of the tablets 130 has two or more inwardly extending projections 138, which form switch actuators. The tablets are frictionally held in either of their two positions of adjustment, shown in full lines and dotted lines in Fig. 2, by leaf springs 140, a number of which may be formed integrally as a comb, the springs being secured to the lower inwardly turned flange of the front plate 46 by rivets 142.

A plurality of switch arms 144, 146 are secured to an insulating plate 148 which is secured to the front frame plate 46. The switch arms 144 and 146 are adapted to engage contact lugs 145 and 147 respectively, the lugs being suitably riveted to the insulating plate 148 as indicated in Fig. 2a. The switch contact arms 144 and 146 are likewise riveted to the insulating plate 148, as best shown in Fig. 6. Suitable openings are formed in the front plate 46 and insulating plate 148 to permit the actuator projections 138 to engage the switch arms 144 and 146. When the tablet 130 is tilted to the position in which it is shown in full lines in Fig. 2, the lower actuator projection 138 will engage the switch arms 144 and swing them away from the contact lugs 145, while when the tablet 130 is swung to its full line position, the upper actuator projection will engage the switch arm 146 and flex the latter away from its contact lug 147. The switch arms 144, 146 and the contact lugs 145 and 147 are preferably provided with rare metal contact

wires which extend at an angle to one another so as to provide substantially a point contact. The switch arms 144 and 146, as well as the contact lugs 145 and 147 are provided with inwardly bent portions forming soldering lugs for the wires connected to these parts.

The tilting movement of the tablets 130 is limited by stops 150, 151 which may be in the form of felt strips extending the full length of the front plate 46, being secured thereto by cementing or in any other suitable manner. A name plate supporting bar 152 has lugs 154 thereon, the lugs being secured to the top plate 44 and front plate 46 by screws 48. A name plate 156 of generally inverted trough shape resiliently engages the edge of the supporting bar 152 so that it will normally be frictionally retained in position, but may be slid longitudinally from the supporting bar 152 should it become desirable or necessary to replace it. The name plate 156 preferably has tablet indentifying indicia stamped or marked thereon to enable ready identification of the control functions of the various tablets 130.

The ends of the keyboard assembly are covered by end blocks 158 and 160 which are preferably made of a molded plastic and which prevent longitudinal shifting movement of the name plate 156 on its supporting bar 152. The blocks 158 and 160 are suitably secured to the frame structure of the keyboard so that they may be readily detached therefrom.

The tablets 130 and switches operated thereby may be arranged in any suitable manner depending upon the functions to be performed upon shifting the tablet. For example, if three contacts are to be opened when the upper end of the tablet is pushed inwardly (swung counter-clockwise, Fig. 2), the tablet may be provided with three projecting actuators 138 above its pivot shaft 134 and three switch arms 146, with their contact lugs 147, in position to be operated thereby. On the other hand, should it be desired that the tablet should open three switches when it is tilted by pushing its lower end (swung clockwise, Fig. 2), the tablet may be provided with three actuator projections 138 below its pivot, and three switches 144 together with their contact lugs 145 provided for operation by these three actuators. Any other arrangement of the actuators and switches may be made, depending upon the manner in which the switches are to be operated.

Inasmuch as each of the keys is supported by a spring 60 and a spring 61, the keys will have substantially translatory movement when depressed. Excessive tilting or excessive lateral swinging movement of the keys is prevented, due to the fact that their actuators 70 project through the openings formed in the notched bar 27. There is sufficient clearance between the actuator bars 70 and the walls of the openings in the notched bar 27, that some tilting movement of the keys is possible, but such movement is limited to an extent which will not damage the leaf springs 60 and 61. Similarly, the white keys 54 are prevented from being swung laterally to an injurious extent by the inter-engagement of the lugs 110 and the sockets 112 formed in the bosses 113. Thus, while the key mounting is delicate in the sense that the force required to depress the keys is very small, and the key stroke is short, the key mounting is such that the keys may neverthe-

less be carelessly and roughly operated without in any way damaging the action.

The key action is very compact, having been practically constructed so as to have an over-all height of less than $3\frac{1}{4}$ " (i. e. from the top of the black key 52 to the bottom plate 24), but despite the small size of the parts, the keyboard is sufficiently rugged to withstand the normal use and abuse to which it may be expected to be subjected. Despite the fact that each key operates two switches, and each tablet may operate one to three switches, sufficient space is provided within the confines of the main casing frame plates to provide for the numerous wires by which connection to the switches is made. The wires for the switch arms 76 may be formed in a cable in the space adjacent the lugs 92 of these switch arms, while the wires for the tablet operated switches may be formed in the cable located between the shielding guard 102 and the tablet operated switches.

While we have shown and described a particular embodiment of our invention, it will be apparent to those skilled in the art that numerous modifications and variations may be made without departing from the underlying principles of the invention, we therefore desire by the following claims, to include within the scope of our invention all such modifications and variations by which substantially the results of our invention may be obtained through the use of substantially the same or equivalent means.

We claim:

1. In a keyboard for an electrically controlled musical instrument, the combination of a plurality of keys, an actuator secured to each of said keys, a pair of leaf springs extending in a direction perpendicular to the direction of movement of said keys, each of said leaf springs having one end which is rigidly held and the other end secured to said key and actuator respectively, whereby said key will be capable of substantially rectilinear translatory movement upon depression thereof and be restored by said springs, and contact switches operated by said actuator.

2. In a keyboard for electrically controlled musical instruments, the combination of a casing having an opening in the top thereof, a key having a boss projecting through said opening, a pair of key supporting leaf springs, each having one end rigidly secured with respect to said casing, said leaf springs extending substantially perpendicularly to the direction of movement of said key, a switch actuator, means for securing said switch actuator and the free end of one of said leaf springs to said key boss, and an operating connection between the free end of the other of said springs and said actuator.

3. In a keyboard for an electrically controlled musical instrument, the combination of a plurality of switches, a vertically reciprocable actuator for said switches, a pair of leaf springs, each having one end attached to said actuator and its other end rigidly supported, said leaf springs being spaced from one another and extending in a generally horizontal direction, and a key rigidly secured to said actuator.

4. In a keyboard for electrically controlled musical instruments, the combination of a casing having a plurality of vertical frame plates secured therein, a switch arm supported by said vertical frame plates, a vertically reciprocable actuator for said switch arm, a pair of leaf springs each having one end secured to said actuator adjacent the ends thereof respectively, means for

rigidly securing the other ends of said lead springs with respect to said casing, and a key having a part extending freely through said casing and rigidly secured to said actuator.

5 5. In a keyboard for an electrical switch controlled musical instrument, the combination of a casing having a front, rear, top and bottom wall, a plurality of tablets pivotally mounted on the front wall of said casing, an insulating sheet secured inside said front wall, a plurality of switch members secured to said insulating sheet, said front wall and said insulating sheet having registering apertures formed therein, and actuator projections on said tablets adapted to project through said registering apertures and to operate said switch members upon tilting movement of said tablet.

6. In a keyboard for an electrically controlled musical instrument, the combination of a frame, a plurality of vertically movable keys, an actuator secured to each of said keys, a pair of generally horizontally extending leaf springs for each of said keys, said leaf springs having one end rigidly secured to said frame and each having its other end secured to said actuator, whereby said keys will be capable of substantially translatable vertical movement upon depression thereof and will be restored by said springs, and a switch operated by said actuator.

7. In a keyboard for electrically controlled musical instruments, the combination of a frame, a vertically reciprocable key, a pair of key supporting leaf springs, each having one end rigidly secured with respect to said frame, said leaf springs extending substantially horizontally, a switch actuator, means for securing said switch actuator and the free end of one of said leaf springs to said key, and an operating connection between the free end of the other of said springs and said actuator.

8. In a keyboard for an electrically controlled musical instrument, the combination of a plurality of switches, a vertically reciprocable actuator for said switches, a pair of leaf springs, each having one end attached to said actuator and its other end rigidly supported, said leaf springs being spaced from one another and extending in a generally horizontal direction, and a key rigidly secured to said actuator and supported solely thereby.

9. In a keyboard for an electrical switch controlled musical instrument, the combination of a casing having a front, rear, top and bottom wall, a plurality of tablets pivotally mounted on the outside of the front wall of said casing, an insulating sheet secured inside said front wall, a plurality of switch members secured to said insulating sheet, said front wall and said insulating sheet having registering apertures formed therein, actuator projections on said tablets adapted to project through said registering apertures and

to operate said switch members upon tilting movement of said tablet, a plurality of keys having operating parts extending through the top wall of said casing, and switches mounted within said casing and operable by said key parts.

10. In a keyboard for electrical musical instruments, the combination of a frame, a depressible key, a leaf spring support for said key having one end rigidly secured to said frame and its other end rigidly secured to said key, a rigid stop element carried by said frame, and means on said key cooperable with said stop element only when said key is swung sidewardly an excessive extent, thereby to limit the extent of sideward movement of said key and prevent excessive deformation of said leaf spring support.

11. In a keyboard for electrical musical instruments, the combination of a frame, a depressible key of a molded plastic composition and having a boss and a downwardly facing socket, a leaf spring support for said key having one end secured to said boss and the other end thereof secured to said frame, and an upwardly projecting element rigid with said frame and extending partially into said socket, there being sufficient sideward clearance between said projection and the inner walls of said socket to prevent contact between said element and said socket when said key is operated normally, said element and socket cooperating to prevent said key from swinging in a horizontal plane a sufficient extent to cause damage to said leaf spring support.

12. In a keyboard for an electrical musical instrument, the combination of a depressible key, a keyboard frame, a leaf spring having one end secured to said frame and its other end secured to said key, said leaf spring extending in a generally horizontal direction, an actuator secured to said key and extending downwardly therefrom, and a member secured to said frame and having an opening therein receiving said actuator, said opening being slightly larger than said actuator in cross section, whereby said member serves as a means to prevent excessive lateral movement of the portion of said actuator extending there-through without interfering with its normal vertical movement.

13. In an electrically controlled musical instrument, the combination of a supporting plate having an aperture therein, a contact switch secured at one side of said plate and having a movable switch arm extending across said aperture, and an actuating tablet pivotally supported on the other side of said plate and having a projection of insulating material of sufficiently small size freely to extend through said aperture and engage said switch arm to operate said switch upon pivotal movement of the tablet.

LAURENS HAMMOND.
GEORGE H. STEPHENS.