

Feb. 25, 1941.

L. HAMMOND ET AL

2,233,258

ELECTRICAL MUSICAL INSTRUMENT

Filed Sept. 5, 1939

3 Sheets—Sheet 1

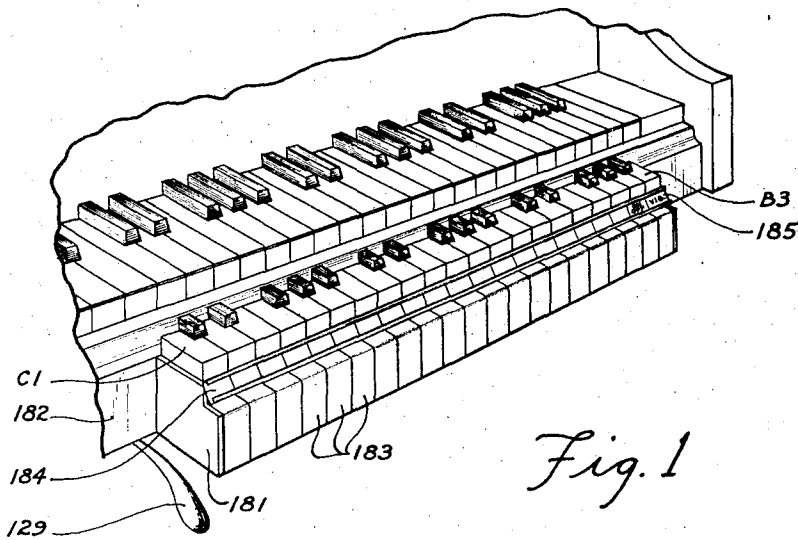

Fig. 1

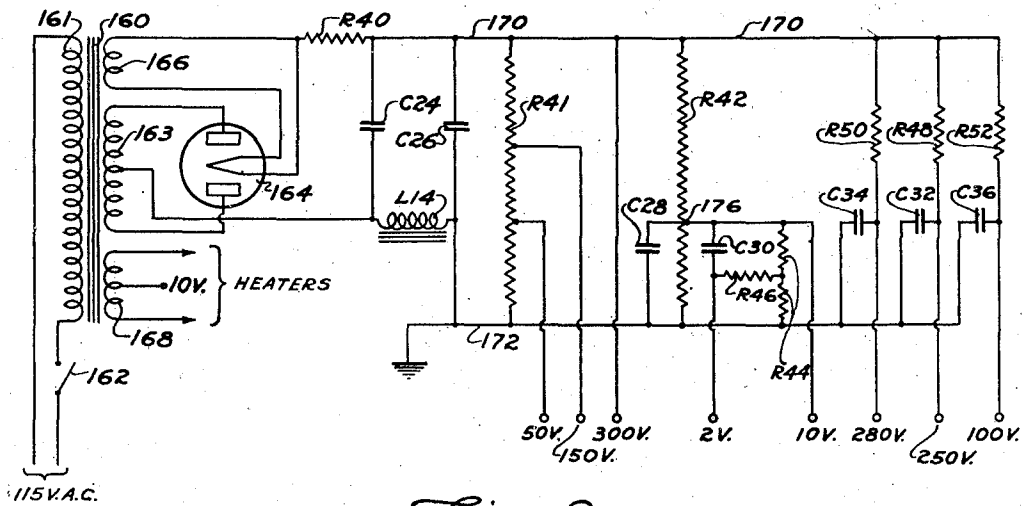

Fig. 2

Inventors
Laurens Hammond & John M. Hanert
By Benjamin F. Wupper
Atty.

Feb. 25, 1941.

L. HAMMOND ET AL

2,233,258

ELECTRICAL MUSICAL INSTRUMENT

Filed Sept. 5, 1939

3 Sheets-Sheet 2

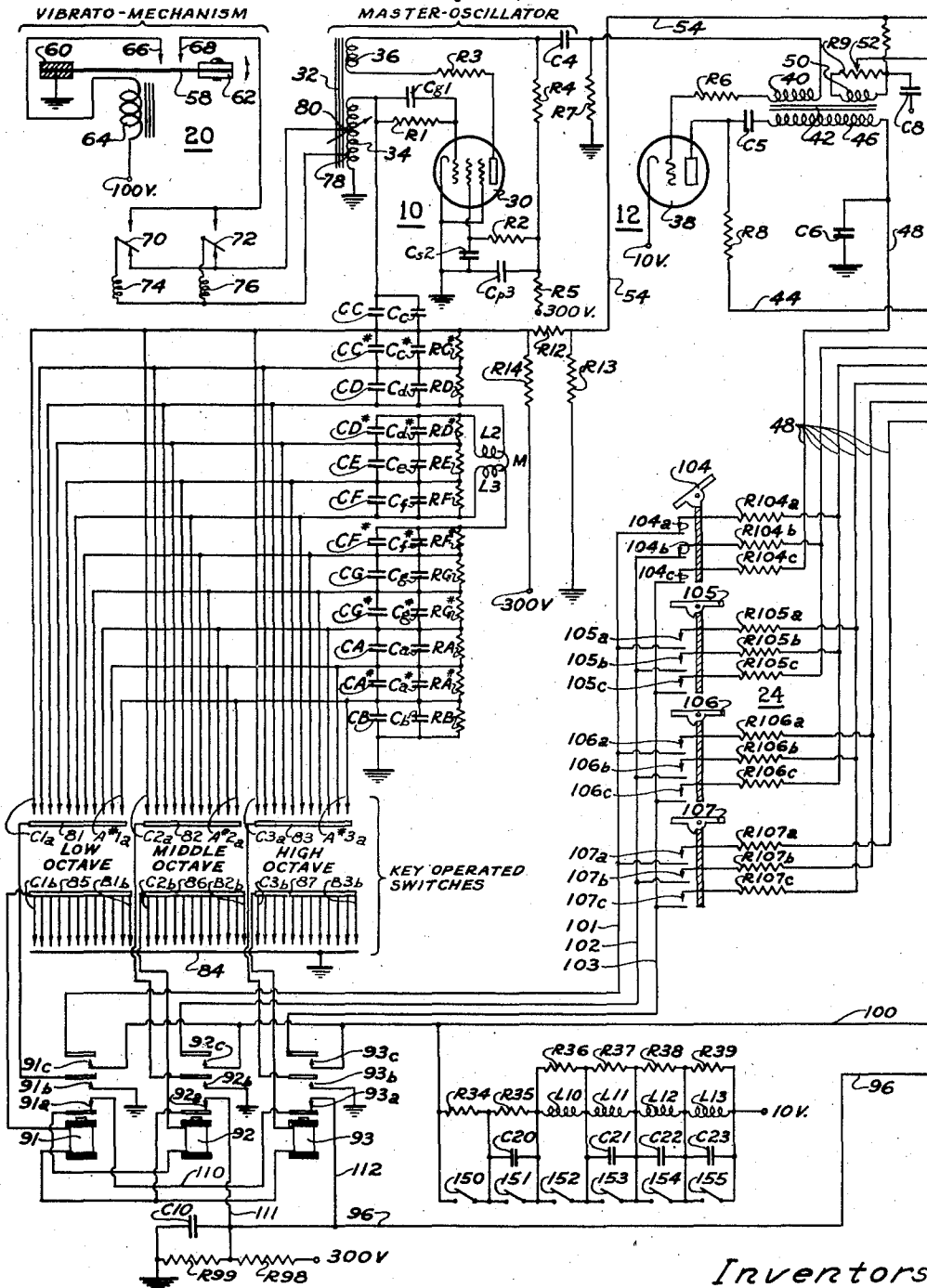

Fig. 3 **Inventors**
 Laurens Hammond & John M. Hanert
 By *Benjamin F. Wupper*
 Atty.

Feb. 25, 1941.

L. HAMMOND ET AL

2,233,258

ELECTRICAL MUSICAL INSTRUMENT

Filed Sept. 5, 1939

3 Sheets-Sheet 3

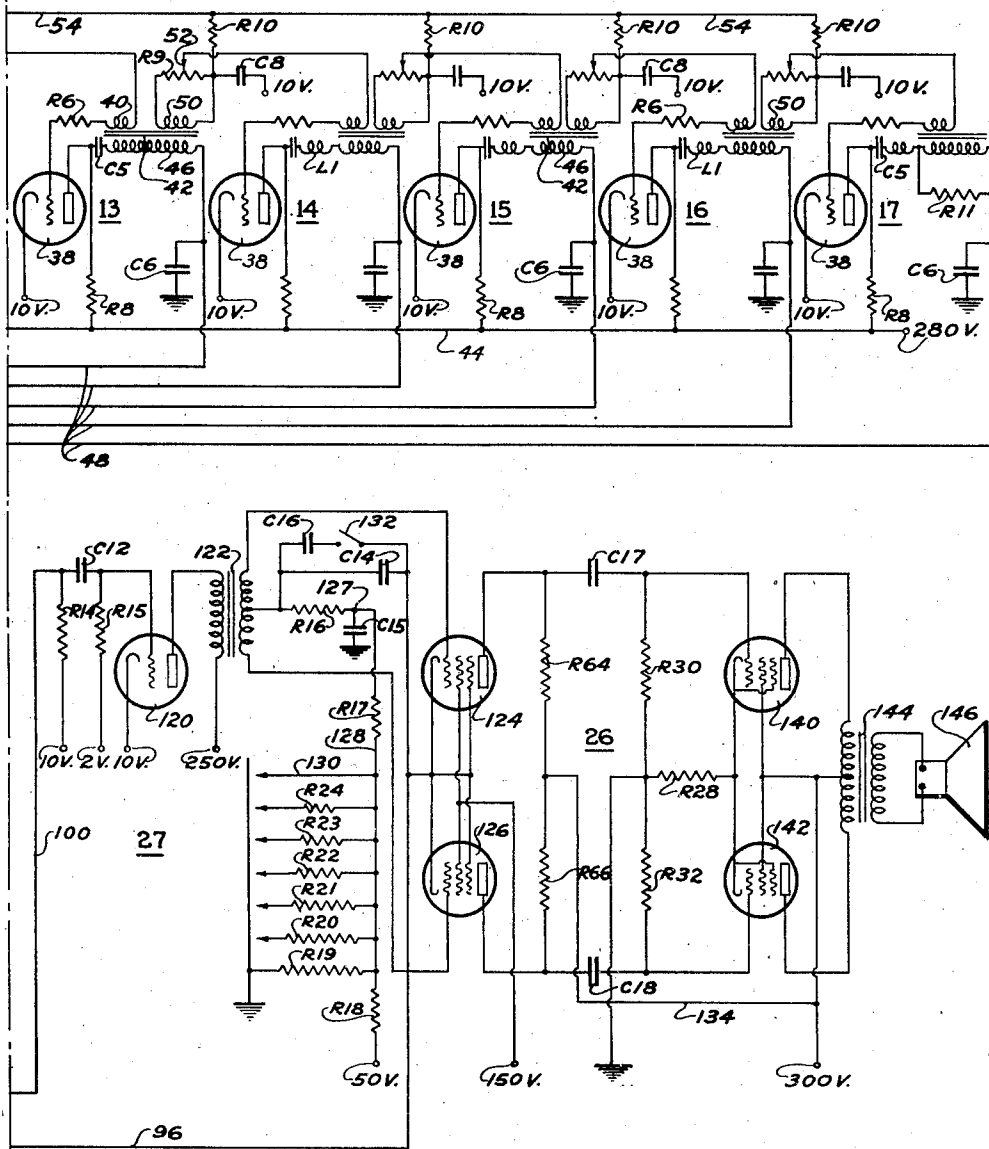

Fig. 3a

Inventors
Laurens Hammond & John M. Hanert
By Benjamin F. Supper
Atty.

UNITED STATES PATENT OFFICE

2,233,258

ELECTRICAL MUSICAL INSTRUMENT

Laurens Hammond, Chicago, and John M. Hanert, Wilmette, Ill.; said Hanert assignor to Hammond Instrument Company, Chicago, Ill., a corporation of Delaware

Application September 5, 1939, Serial No. 293,444

23 Claims. (Cl. 84—1.25)

Our invention relates generally to electrical musical instruments and more particularly to musical instruments of the melody type, and constitutes an improvement on the instrument disclosed in the application of John M. Hanert, Serial No. 274,325, filed May 18, 1939.

It is an object of our invention to provide an improved melody type instrument having a keyboard of a range of several octaves by the use of which any melody may be played.

A further object is to provide an improved electrical musical instrument of the melody type employing a plurality of generators, and utilizing an improved keying system whereby undesirable transients are suppressed both when playing legato and non-legato.

A further object is to provide a keying system whereby the touch of the player exercises a control over the envelope of the tone.

A further object is to provide an improved electrical musical instrument of the melody type having a plurality of frequency generators, a keyboard of a range greater than that of any one of the generators, and key circuits controlled by the keys for selectively keying the signal from one or more of the oscillation generators.

A further object is to provide an improved keying system for an electrical musical instrument in which relays are employed and in which the current flow through the winding of the relay has an effect upon the amplification of the output of the instrument independent of the completion of circuits by the relay.

A further object is to provide an electrical musical instrument having a variable gain electron discharge tube amplifier in its output, in which the key completed circuits energize relays for causing the transmission to the output of the desired signal, and in which the energization of the relay, independent of the switch contacts operated thereby, controls the gain of said electron discharge device.

A further object is to provide an electrical musical instrument employing an oscillator, controlling the frequencies produced by the instrument, with an improved vibrato producing means.

A further object is to provide an oscillator having improved means for periodically shifting its frequency between selected predetermined limits, in which the mean frequency remains constant, irrespective of which limits are selected.

A further object is to provide an improved relay keying system in connection with a keyboard, all the keys of which are free to be depressed

at all times, without requiring the use of mechanical key locking arrangements to prevent the player from simultaneously depressing two or more keys in adjacent selected octave groups.

A further object is to provide an improved relay keying system in connection with a keyboard, all the keys of which may be rapidly operated, having no associated mechanically operated switches common to a plurality of said keys, to retard the maximum speed of action on said keys.

A further object is to provide an improved relay keying system for use with a keyboard in which no serious restrictions are imposed on the player concerning the number of keys which may be simultaneously depressed in playing a melody such as, for instance, two keys being momentarily simultaneously depressed in playing from one to the other of said keys.

A further object is to provide an improved keying system for an electrical musical instrument in which the time delay between the initial current flow through the relay energizing coil and the subsequent operation of contacts associated with the armature of said relay is utilized in a manner to eliminate undesirable transients from the output of the instrument.

A further object is to provide an improved keying system for electrical musical instruments in which no substantial time delay occurs between breaking a contact in series with a relay winding, and a change in voltage occurring in a circuit associated with the relay winding.

A further object is to provide an improved keying system for electrical musical instruments in which simplification and reduction of cost is effected by providing a relay in which one function associated with the energization of the relay is accomplished by taking advantage of a change in voltage occurring in a circuit associated with the winding of the relay.

A further object is to provide an improved relay keying system for an electrical musical instrument in which there is no period of silence occurring when two keys are simultaneously depressed in adjacent selected groups of keys.

Other objects will appear from the following description, reference being had to the accompanying drawings in which:

Figure 1 is a perspective view of the instrument shown attached to a piano;

Figure 2 is a wiring diagram of the power supply system for the instrument; and

Figures 3 and 3a together constitute a wiring diagram of the instrument.

General Description

As shown in Figure 1, the keyboard for the instrument comprises three octaves of the customary piano keyboard, the keys being designated C1 to B3 inclusive. The actual pitches of the tones produced upon depression of these keys may be varied as desired by register changing switches such that the notes produced upon depression of the keys may be selectively in the bass, tenor, or treble registers. As a result, the keyboard may, by the use of four such register controlling switches, be made to sound any note within a six octave range.

In general, the instrument comprises a single master oscillator 10 which is connected to control a series of six relaxation oscillators 12 to 17 inclusive, which are connected in cascade and have their frequencies of oscillation stabilized by a signal derived from the master oscillator 10. Instead of the relaxation oscillators disclosed herein, any other suitable type of oscillator whose frequency may be readily stabilized such as gas tube oscillators, multivibrators and the like, might be utilized. The frequency of oscillation of the master oscillator 10 may be periodically shifted at a vibrato rate by means of a vibrato mechanism 20, and this frequency shift of the master oscillator is of course proportionally present in the frequencies of oscillation of the controlled oscillators 12 to 17 inclusive.

Each of the keys C1 to B3 controls the performance of several functions:

(a) It selects a tuning circuit for the master oscillator 10, and at the same time selects the appropriate grid bias potential for the controlled oscillators 12 to 17 inclusive, so that these controlled oscillators are conditioned readily to be stabilized by the frequency of the master oscillator;

(b) Thereafter, it closes a contact which energizes a relay, the energization of which starts to turn the amplifier on with a predetermined rate of attack;

(c) The energization of the relay causes completion of circuits which render the preselected tuning circuits effective, keys the signal from the appropriate oscillator to the amplifier, and causes a circuit to be broken which renders ineffective the depression of another key in an adjoining octave group, which may be depressed at the same time.

The instrument also includes a selectively operable switching mechanism 24 for determining the register in which the instrument is played, and for providing musical effects in which one or more octaves of the note may be simultaneously sounded. The output of the instrument is supplied to an amplifier 26, volume control 27, and electroacoustic translating means. Power for operation of the various circuits is supplied by a power pack shown in Fig. 2.

Frequency Generating System

The controlling oscillator comprises a tube 30 which may be a pentode of the 6J7G type illustrated, the input and output circuits of which are coupled by means of an oscillation transformer 32 having a primary 34 and a secondary 36. The frequency of oscillation is determined principally by the inductive reactance of the oscillation transformer 32 and the capacitive reactance of condensers CC to CB for the indicated notes of the octave, together with their parallel fine tuning condensers Cc to Cb. These condenser groups are connected in series, and de-

pending upon the number of these condenser groups which are connected in series, tune the oscillator 10 to one of the semi-tone notes of an octave. The frequencies thus generated constitute the semi-tones of the highest octave of frequencies available in the instrument which are 2093 to 3951 c.p.s.

Bias to tube 30 is supplied by means of grid leak R1 which is in parallel with a grid condenser Cg1. Screen bias to tube 30 is supplied through voltage dropping resistor R2 and filter condenser Cs2. Plate load on tube 30 comprises resistor R3, in series with winding 36 of oscillation transformer 32, and resistance R4 which is connected to filter condenser Cp3 and filter resistance R5 to a terminal 366V of the power supply, at approximately 300 volts potential. The suppressor grid of tube 30 is connected to the cathode.

The output of the oscillator 10 is coupled to the grid circuit of the controlled oscillator 12 through a condenser C4. The oscillator 12 comprises a triode 38 of the 6J5G type, the grid circuit of which includes a protective resistor R6, a secondary winding 40 of an oscillation transformer 42, and grid resistor R7, which is connected to ground. The cathode of the tube 38 is connected to a terminal 10V in the power supply system which is at a potential of 10 volts positive with respect to ground, there thus being 10 volts negative bias on the grid of tube 38.

Current is supplied to the plate of tube 38 through a conductor 44, which is connected to terminal 280V of the power supply system, through a timing resistor R8. The rate of relaxation of the oscillator 12 is controlled by the relative values of the timing resistor R8 and the capacitance of a timing condenser C5 which is in series with condenser C6 through the primary winding 46 of the transformer 42.

An output signal is derived from the oscillator 12 through a conductor 48 which is connected to a point intermediate the condenser C6 and the secondary winding 46. The output of the oscillator 12 appearing across the condenser C6 will be generally of saw-tooth shape, thus comprising a fundamental frequency with a long series of harmonic over-tones of progressively decreasing amplitude. The value of condenser C6 is large relative to that of C5, and thus does not have an appreciable effect upon the rate of relaxation of the oscillator 12.

The constants of the oscillator circuits 12 and the potentials supplied thereto, are such that the relaxations occur at the same frequency as the master oscillator 10. In other words, the signal derived from the master oscillator 10 and impressed upon the grid of the tube 38 through the coupling condenser C4 serves to trip the relaxation oscillator for each positive impulse received.

The transformer 42 has a tertiary winding 50 which is shunted by a resistance R9, of a value in the order of approximately 100 ohms. The secondary 40 may have approximately one half, while the tertiary winding 50 may have approximately one eighth as many turns as the primary 46. The resistor R9 shunted across the tertiary winding is reflected into the plate circuit of the tube 38 as a load impedance.

The oscillator 13 may be substantially identical with the oscillator 12 except that it will be noted that it is coupled to the oscillator 12 through an adjustable tap 52 on the resistance R9. The adjustment of the tap 52 will be such

that oscillator 13 will be properly timed to relax at one half the frequency of oscillator 12. Such adjustment is made when the instrument is assembled and will not ordinarily need to be re-adjusted. The biasing potential for the oscillator 13 is supplied from a conductor 54 through a filter resistor R10. A filter condenser C8 has one terminal connected to a fixed potential terminal 10V of the power supply, and its other terminal connected to the tertiary winding 50 of transformer 42. The potential on the conductor 54 is varied depending upon the key depressed, as will appear more fully hereinafter, so that the oscillator 13 will relax at one half the rate of oscillators 16 and 12, regardless of the frequency to which the master oscillator 10 is tuned.

The relaxation oscillator 14 is similar to oscillator 13, except for differences in the values of the timing resistors R8 and condensers C5, and in the number of turns in the windings of its transformer 42. The relaxation oscillator 14 also differs from the oscillator 13 by the inclusion of a small inductance L1 in series with the primary winding 46 of the transformer 42 associated with the oscillator 14. This small inductance serves to remove musically undesirable high frequencies in the generally saw-tooth wave shape occurring across its condenser C6.

The oscillators 15, 16 and 17 are similar to the oscillator 14, being similarly connected in cascade, and having circuit elements of such values that they relax at frequencies in octave relationship. It will be noted, however, that transformer 42 associated with the relaxation oscillator 17 does not have a tertiary winding but instead, has a high resistance R11 shunted across its primary winding to provide the plate load corresponding to that provided by the resistance R9 for the relaxation oscillator 12.

The bias potential upon the conductor 54, in order to make certain that the relaxation oscillators 13 to 17 inclusive safely follow changes in frequency of the relaxation oscillator 12, must be varied as the frequency of the master oscillator 10 and of the oscillator 12 is varied. The conductor 54 is connected to a point intermediate resistors R12 and R13 which together with a resistance R14 form a voltage divider connected between the terminal 300V of the power supply and ground. Associated with these voltage divider resistors is a further voltage divider resistance system consisting of resistors RC# to RB inclusive, connected in series between R12 and ground. The voltage appearing intermediate resistances R14 and R12 will be determined by the particular key which is depressed, as will be described hereinafter.

It is to be noted that tuning is accomplished by connecting selected condensers CC to CB to ground, and that such connection likewise determines which of the resistors RC# to RB are effective in the voltage dividing mesh provided by these resistors as well as the resistors R12, R13 and R14. All of the resistors in this voltage dividing mesh are so chosen that resistors RC# to RB inclusive do not constitute appreciable loads (to alternating current of the master oscillator frequency) upon tuning condensers CC# to CB, and Cc# to Cb. In this way, the frequency of oscillator 10 is determined substantially by the reactive elements of the tuning system and not appreciably by the resistances RC# to RB, R12, R13, or R14, and thus good frequency stability for oscillator 10 is assured, be-

cause of the high Q (sharpness of resonance) of this tuning circuit.

It will be noted that inductances L2 and L3 are inserted between the tuning condensers CD and CD#, and CF and CF# respectively, and that these inductances are wound together so as to form a mutual inductance M between them. These inductances are very small compared to the inductance of oscillation transformer 32, and thus have inappreciable effects upon the tuning of oscillator 10. Their function is to suppress the spark incident to tuning the oscillator 10.

It will be noted that when the number of effective condensers CC to CB in the tuning circuit is changed, the circuits by which such changes are made are subjected to the residual D. C. voltage on such condensers as are shunted out of the circuit by virtue of the bias voltage divider resistors RC# to RB connected in shunt with them. The inductances L2 and L3 either singly, or both mutually, depending upon which group of condensers is shunted, thus serve as a means to limit the discharge of the condensers to a rate such as will not cause excessive sparking at the tuning contacts.

Vibrato mechanism

The frequency of the oscillator 10, and hence of all of the controlled oscillators 12 to 17 inclusive may, whenever desired, be periodically shifted throughout a small range, in the order of 3%, at a vibrato periodicity of approximately 7 c. p. s. to provide the vibrato in the tones ultimately produced.

The vibrato mechanism comprises a vibratory magnetic metal reed 58 secured to a suitable rigid grounded support 60 and having a weight 62 adjustably secured thereto so as to permit variations in the vibrato periodicity. The reed 58 is maintained in vibration by an electro-magnet 64, one end of the winding of which is connected to the terminal 100V of the power supply system. The other end of the winding of the electro-magnet 64 is connected to a contact 66 which makes contact with the reed during the upper portion of its vibratory oscillation, and since the reed is grounded at the support 60, current flows through the coil of the electro-magnet 64 and attracts the reed 58, whereupon its contact with the contact 66 is broken.

A second contact 68 is provided for engagement with the reed 58 and is thus periodically grounded through the reed at the rate of vibration of the reed. This contact 68 is connected to single-pole double-throw switches 70 and 72 by which the contact 68 may be made to interrupt the circuit through a coil 74 of relatively high inductance, or through a coil 76 of lesser inductance. The coils 74 and 76 are connected in parallel with approximately 13% of the turns of the primary 34 of transformer 32 at a tap 78.

When either of the switches 70 or 72 is in its off position, the inductance 74 or 76 associated therewith is connected to a tap 80 on the primary 34 so as to cause the oscillator 10 to oscillate at a frequency which is the mean of the frequencies at which it oscillates when the inductance 74 (or 76) is periodically connected between the tap 78 and ground by the contact 68. The number of turns between ground and tap 78 is 29.1% of the number of turns between ground to tap 80. The switches 70 and 72 are manually operable, and may be used singly or together, to provide three different degrees of vibrato. The taps 78 75

and 66 are at such points upon the primary 34 that the mean frequency of oscillator 10 will be the same, irrespective of the positions of the switches 70 and 72. The reed 58 may be manually started in vibration or may be provided with some means to start it automatically whenever the instrument is placed in operation.

Key circuits

As previously stated, and as shown in Fig. 1, the instrument is composed of a plurality of octaves of keys C1 to B3 preferably of the general arrangement utilized in piano and organ keyboards, and is herein illustrated as having a gamut of three octaves, although the keyboard could be reduced or extended to any desired length. Since the instrument is of the melody type in which more than two keys are seldom, if ever, simultaneously depressed intentionally, the keys C1 to B3 may be very much shorter than the standard piano keys. By virtue of the size and positioning of the keys they may readily be depressed simultaneously with the depression of the piano keys.

The keys C1 to B3 are mounted in a suitable keyboard frame 181 which may be conveniently attached to the front rail 182 of the keyboard of a standard piano, organ, or similar instrument. The frame 181 carries a plurality of pivoted tablets 183 which are utilized for the manual operation of the various control switches, such as the vibrato switches 70, 72, and the various other switches, described hereinafter, whereby the tone quality is varied, the rate of attack of the tones controlled, and the instrument otherwise conditioned to produce tones of the desired characteristics.

Above the tablets 183 is a channel-shaped guide 184 to receive blocks 185 bearing indicia identifying the tablets 183 as to the nature of the controls effected thereby.

It will be noted that the keys C1 to B3 are spaced to register with the corresponding piano keys, but are very much shorter than the piano keys. The two sets of keys are closely adjacent one another so that the musician may conveniently play simultaneously on both keyboards with one hand.

While the type of keys and keyboard disclosed herein is particularly well adapted for the control of a melody instrument, any other suitable keyboard may be used. It should be noted, however, that when a piano type of keyboard is used, the black keys should be made narrower than usual so that a white key located between two adjacent black keys may easily be depressed without depressing either of the black keys.

Each of the keys C1 to A3 (except keys B1 and B2), operates two switches in sequence. The switches which are closed first upon depression of these keys are illustrated in Fig. 3 as contacts C1a to A3a respectively, while the contacts which are subsequently made by keys C1 to B3 are designated C1b to B3b respectively. The contacts C1a to A1a are adapted to make contact with a bus bar 81, while the contacts C2a to A2a are adapted to make contact with bus bar 82, and similarly, the contacts C3a to A3a are adapted to make contact with a bus bar 83. All of the second made contacts of each of the keys, i. e., the contacts C1b to B3b are adapted, upon depression of the key, to contact with a grounded bus bar 84.

The contacts C1a to A1a are connected respectively in parallel with the contacts C2a to

A12a and C3a to A13a, and respectively to the corresponding terminals of the condensers CC to CA3. When no key is depressed, the oscillator 10 is tuned to oscillate at the frequency of the note B (3951 c. p. s.), as determined by the capacitance of all of the tuning condensers taken in series. Therefore, when depressing a B key, it is not necessary to provide tuning contacts for making connection with the buses 81, 82 and 83. However, it is necessary, for reasons which will appear hereinafter, to provide contacts B1b, B2b, and B3b. It will be noted that the contacts C1b to B1b for the first octave are connected together by a conductor 85, while the corresponding contacts for the second octave are connected together by a conductor 86, and those for the third octave of keys by a conductor 87.

Associated with the first octave of the keyboard is a relay 91, having a break contact 91a and two make contacts 91b and 91c. A similar relay 92 having a break contact 92a and two make contacts 92b and 92c is associated with the second octaves of the keys, while a relay 93 having a similar break contact 93a and two make contacts 93b and 93c, is provided for the third octave of keys. The windings of the relays 91, 92 and 93 each have one end thereof connected to the conductors 85, 86 and 87 respectively. The other end of the winding of relay 91 is connected through the normally closed contact 92a and conductor 111 to a conductor 96 which is connected to a positive potential terminal 300V of the power supply through one section R98 of a voltage divider, the other section R99 of which is connected to ground, section R99 being shunted by a conductor C16.

Thus, upon depression of any of the keys in the first (low) octave, the relay 91 will be energized, providing the relay 92 has not been energized, and its contacts 92a are thus closed. Energization of the relay 91 results in the closure of contact 91b which connects the bus 81 to ground, thus rendering effective the tuning of the oscillator 10 by the particular condensers taken in series, dependent upon the particular key of the first octave which is depressed. At the same time, the closure of the contacts 91b affects the grid bias of the controlled oscillators 12 to 17 inclusive, since the grid biasing resistors RC3 to RB are connected in parallel with the tuning condensers. Due to the fact that these biasing resistors are in parallel with the tuning condensers, there will be a certain time lag whenever one of the playing keys is depressed, before the biasing potential determined by the depressed key is impressed upon the conductor 54, since a very small fraction of a second is required for the discharge of the tuning condensers through the biasing resistors. This delay is, however, so short as not to be of any significance because the resistors RC3 to RB are of very low value, in the order of 5,000 to 15,000 ohms, and thus form a relatively low resistance path for the discharge of these tuning condensers. On the other hand, the biasing resistors RC3 to RB cannot be made of too low value compared to the impedance offered by the tuning condensers, as these resistors would then lower the Q of the oscillator tuning circuit.

Energization of the relay 91 also results in the closure of the contacts 91c, one of which is connected to the output signal conductor 100 which is connected to the amplifier as will be more fully described hereinafter. The other contact of the contacts 91c is connected to a con-

ductor 101 which is adapted to receive signals from the controlled oscillators 14 to 17 inclusive, depending upon which of a plurality of register controls is operated.

5 It will be noted that there are four register control actuators 104, 105, 106 and 107, each actuating three switches which are designated by the reference character of the actuator, followed by the letter a, b, or c. Each of the switch contacts 104a, b, c to 107a, b, c, is connected to one of the six conductors 48 which constitute the signal output conductors of the controlled oscillators 12 to 17 inclusive through amplitude controlling and non-robbing resistors R104a, etc., associated with the switches 104a, etc., respectively.

10 There is a conductor 102 for the second or middle octave of keys, which corresponds to conductor 101 for the first or low octave of keys, and a similar conductor 103 for the third or high octave of keys. When, for example, the register control 104 is moved to the position in which it is shown in Fig. 3, the signal from the controlled oscillator 14 is impressed upon conductor 101, the signal from the oscillator 13 is impressed on the conductor 102, and the signal from the oscillator 12 is impressed upon conductor 103.

15 Upon operating the register control 105, it will be noted that the conductors 101, 102 and 103 will receive signals from controlled oscillators each one octave lower than when the register control 104 was operated. In a similar manner, operation of the register controls 106 and 107 will cause signals to be impressed upon the conductors 101, 102 and 103 which are each two and three octaves lower respectively, than are connected to these conductors, when the register control 104 is operated. It will be noted that conductor 102 is connected to relay contact 92c while conductor 103 is connected to relay contact 93c.

20 As previously pointed out, depression of a key in the lower octave, or first octave of keys, will not result in the energization of the relay 91 if the relay 92 is energized. Similarly, the depression of a key in the highest, or third octave of the keyboard, will not result in the energization of the relay 93 if the relay 92 is energized, since it will be noted that one terminal of the winding of relay 93 is connected to the conductor 87, while the other terminal thereof is connected to the break contact 92a which, when relay 92 is energized, is open.

25 Similarly, relay 92 cannot be energized unless both relays 91 and 93 are de-energized, because its energizing circuit leads from conductor 86 through the winding of relay 92 to the normally closed contact 91a through conductor 110, through the normally closed contact 93a and hence through conductor 112 to the conductor 96. Thus, if either relay 91 or the relay 93 is energized, its contact 91a or 93a will be open, and hence the relay 92 cannot be energized. By preventing the simultaneous energization of two adjacent relays, the transmission of undesirable transients to the output of the instrument is prevented, as will be pointed out more fully hereinafter.

30 Whenever any one of the relays 91, 92, or 93 is energized, its winding is thereby connected in parallel with resistor R99, decreasing the voltage drop across this resistor, and consequently raising the potential of the conductor 96.

Amplifier and volume controls

The conductor 96 leads to the amplifier 28, being connected to the cathodes of an intermediate push-pull stage thereof. The amplifier receives its signal through conductor 100 which is connected to the grid of the first stage amplifying tube illustrated as a triode 120, and which may be of the 6J5G type, through a blocking condenser C12, the conductor 100 being connected to terminal 10V of the power supply through a load resistor R14. The grid of the tube 120 is connected to terminal 2V of the power supply through a grid resistor R15.

The cathode of tube 120 is connected to terminal 10V of the power supply, while its output or plate circuit is connected to the primary of a transformer 122, the other end of the primary being connected to the terminal 250V of the power pack. The secondary winding of the coupling transformer 122 has its terminals connected respectively to the grids of push-pull amplifier tubes 124 and 126, which may be pentodes of the 6K7G type, having a remote cut off control grid characteristic. The cathodes of the tubes 124, 126 are connected to a center tap of the secondary of transformer 122 through a condenser C14, the cathodes also being directly connected to the conductor 96.

The center tap on the secondary of the transformer 122 has connected thereto, through a resistor R16, a mesh for expression or volume control. This mesh comprises a condenser C15 having one terminal grounded, and its other terminal 127 connected to the resistor R16, and a resistor R17 which is connected between the condenser C15 and a conductor 128. The conductor 128 is connected to terminal 50V of the power pack through a resistor R18. The conductor 128 is connected to ground through a resistor R18 and may, upon operation of the expression control lever 129, be connected to ground through one or more of resistors R20 to R24, and when the swell pedal is closed (i. e. at lowest volume position), is connected to ground through a conductor 130.

35 It will be understood that upon operation of the swell pedal, the contacts on the resistors R20 to R24, and on the conductor 130, are closed sequentially in the order named, and opened in the reverse order. In so doing, they change the potential upon the conductor 128 from a maximum of approximately 50 volts to a minimum of ground, or zero potential. The resistors R18 to R24 inclusive thus form a variable, voltage divider circuit.

40 Resistor R17 and condenser C15 function to limit the rate of change of potential at terminal 127. Resistor R17 is in series with the swell pedal resistor mesh, and serves in conjunction with condenser C15, to cause the rate of potential change at the terminal 127 to be approximately uniform as the swell pedal is moved from step to step. The potential at point 127 determines the grid bias applied to the control grids of push-pull tubes 124 and 126. These tubes are of the variable mu or remote cutoff type, and advantage is taken of this feature in providing a simple swell or volume control system which will operate over a wide range such as 48 db., by varying the grid bias to tubes 124 and 126.

45 By making gradual the rate at which this grid bias changes, the swell or volume control may be simplified into a relatively small number of steps, and still secure a wide range of volume without undesirable sudden changes in volume

occurring when the swell or volume control lever 119 is moved from one position to another. Thus, if resistors R18 to R24 inclusive are so chosen as to provide successive 8 db. changes in volume, a wide range of volume is provided with only six contacts. C15 is so chosen that volume changes are sufficiently gradual, but yet are not too slow to prevent the volume from substantially following the swell pedal position to produce desired rapid dynamic changes in the musical tone being rendered. The control grid bias on tubes 124 and 126 is determined not only by the swell pedal mesh previously described, but by the potential on the conductor 96 which, as previously described, is determined by the voltage divider mesh consisting of resistors R98 and R99. The voltage of the conductor 96 is, however, not determined solely by the resistors R98 and R99, but is also changed whenever any of the relays 91, 92 and 93 is connected in shunt with R99 upon depression of any one of the keys.

When none of the keys is depressed, the voltage on the conductor 96 is such as to bias the tubes 124 and 126 beyond cutoff irrespective of the setting of the volume control. When, however, a key is depressed, the voltage on the conductor 96 becomes more positive because of the shunting of the relay winding impedance across R99, and thus the effective bias on the grids of tubes 124 and 126 decreases, with resultant increase in the signal output of the tubes 124 and 126.

The rate at which the signal increases in the outputs of tubes 124 and 126 is determined by the time constant of C14 and R16. When a playing key is depressed, the control grids of tubes 124 and 126 remain at cutoff potential because condenser C14 is connected to these grids through the transformer secondary and not through a resistor, which might limit the rate of change of potential. However, after the key has been depressed, the transient voltage which was supplied through condenser C14 will disappear and the bias upon the grids of tubes 124 and 126 will change to their operating potential at a rate determined by R16 and C14.

When it is desired to impart a very slow string-like attack to the musical tones produced, a condenser C16, one plate of which is connected to the mid-point of the secondary of the transformer 122, is connected by means of a switch 132 to the cathodes of tubes 124 and 126. This condenser will then be in parallel with condenser C14, and thus the rate at which the operating bias is applied to the control grids of tubes 124 and 126 will be slower. Switch 132 may be manually operable by the player. When releasing the key, the rate at which tubes 124 and 126 cut off is determined by condenser C10 which is in parallel with resistor R99. It will be noted that tubes 124 and 126 are connected in push-pull so that changes in the D. C. component of the plate current in these tubes does not have any transient effect upon their signal output.

The screen grids of the tubes 124 and 126 are connected to a terminal 150V of the power supply system, while the suppressor grids thereof are connected directly to the cathodes. Plate current is supplied to the tubes from a terminal 300V through a conductor 134, which is connected to the plates of the tubes 124 and 126 by load resistors R64 and R66 respectively. The signal output of the push-pull amplifiers 124 and 126 is supplied to the grids of the power output tubes 140 and 142 connected in push-pull ar-

angement through blocking condensers C17 and C18.

The cathodes of the tubes 140 and 142, which may be pentodes of the 6F6G type, are self-biased above ground potential through a common resistor R28, while the grids of the tubes 140 and 142 are connected to ground through grid resistors R30 and R32 respectively. The values of the grid resistors R30 and R32 with respect to the values of condensers C17 and C18 respectively should be such that the sudden changes occurring in the potentials on the plates of the tubes 124 and 126 will not result in altering the potential on the grids of tubes 140 and 142 for an appreciable length of time.

The suppressor grids of the tubes 140 and 142 are internally connected to their cathodes, while their screen grids are connected to the terminal 300V of the power supply system. The plates of the tubes 140 and 142 are connected to the terminal 300V through a connection to the mid-point on the primary of push-pull output transformer 144. The secondary of the transformer 144 is connected to the voice coils of a speaker 146. The field coil of the speaker 146 may constitute an inductance in the power supply as will appear hereinafter.

Having described in general the construction of the amplifier, it will now be more clearly understandable why the relays 91, 92 and 93 are so connected that energizing one relay makes it impossible to energize adjacent relays by depressing keys in adjacent octave groups of keys.

The reason for providing these mutual interlocking circuits is to effectively suppress undesirable transients which might occur when the player, through a legato style of playing, causes two keys in adjacent octave groups to be simultaneously depressed. If these interlocking circuits were not provided, undesired signals or undesired changes in tuning would occur. It will be noted that each time a player plays across from one octave group of keys into an adjacent octave group of keys, the amplifier will momentarily be cut off when the first mentioned key is released, and then again rendered effective when the relay associated with the second mentioned key is energized. Thus, the old signal is turned off with a controlled decay rate and the new signal is turned on with a controlled attack rate, as determined by the condenser C16, resistors R99 and R16 and condenser C14. It will be noted that each of the relays 91, 92 and 93 is interlocked with its adjacent relay, but that the relays 91 and 93 are not interlocked and it is therefore possible, if the player should depress keys in both the lowest and the highest octave, to energize both relays 91 and 93. Such energization of these relays will cause the potentials on the cathode of tubes 124 and 126 to become very positive, causing tubes 124 and 126 to distort the signal. It is not contemplated, however, that the player in the normal use of the instrument shall play legato from a note in the lowest octave to a note in the highest octave.

As previously described, upon depression of a key—for example, C1—its switch C1a will be closed before its switch C1b is closed, and upon release of the key, the switch C1b will open before the switch C1a opens. By having the biasing potential on tubes 124, 126 controlled by the current flow through the windings of the relays 91, 92 and 93, the bias potential begins to change immediately upon opening of the switch C1b, and will substantially reach cutoff potential at

a non-transient producing rate by the time that switch contact C1a is opened, and by the time that the contacts 91b and 91c open.

If the tubes 124, 126 were not biased substantially to cutoff by the time switch C1a is opened, the oscillator 10 would begin changing its frequency to that of the note B, and thus an undesirable pitch change would be heard during the interval between the opening of the switch C1a and the time that the biasing potential on tubes 124 and 126 reached cutoff.

Tone control system

It will be recalled that the signals provided by the controlled oscillators 12 to 17 inclusive are of generally saw-tooth shape, thus constituting a fundamental frequency combined with a plurality of harmonic frequencies of progressively decreasing amplitude. Thus, a considerable variation in the quality of the tone may be effected by means of resonant filter circuits which tend to pass selected frequencies to a greater or lesser extent. Some of these circuits may operate in the manner of ordinary tone controls on radio receiving sets.

As shown in Figure 3, this tone control system comprises a plurality of resistors R34 to R39 inclusive, a plurality of inductances L10 to L13 inclusive, a plurality of condensers C20 to C23 inclusive, and controlling switches 150 to 155 inclusive. The switches 150 to 155 inclusive operate individually and selectively to permit the signal impressed on conductor 100 to develop across the capacity-inductance resistance mesh associated therewith.

For example, when switch 150 is open, the signal on conductor 100 will have no frequency characteristic impressed upon it because element R34 is a pure resistance. When switch 151 is opened, the signal on conductor 100 will be altered in a manner to emphasize the low frequencies relative to the high frequencies. When switch 152 is opened, the signal on conductor 100 will be altered in a manner to emphasize the high frequencies relative to the low frequencies.

When switch 153 is opened, the signal on conductor 100 will be modified such as to resonate a band of frequencies lying adjacent to the resonant frequency of condenser C21 and inductance L11. The sharpness of resonance is controlled by resistance R37 which is in parallel with C21 and L11. This resonant frequency may preferably be in the order of 3000 c. p. s. Similarly, when switch 154 is opened, the signal upon conductor 100 will be resonated by condenser C22 and inductance L12 and R38. The resonant frequency here preferably is in the order of 1000 c. p. s. In a like manner, when switch 155 is opened, a resonant effect in the order of 200 c. p. s. will be impressed upon the signal on conductor 100. It is to be noted that these switches may be opened by the player individually or in any desired combination.

Operation of keying system

Upon depression of a playing key, for example the key G2, the contact G2a is first closed, thus connecting all of the condensers CC and Cc to CG and Cg, together with associated biasing resistors RC# to RG to the movable contact arm of relay switch 92b.

However, such connection does not change the tuning of the oscillator 10, since at this instant the relay contact 92b is open. Further depression of the key G results in closure of the switch

G2b, whereupon a circuit from the grounded bus bar 84 through the switch G2b, conductor 86, winding of relay 92, closed relay switch 91a, conductor 110, closed relay switch 93a, conductor 112, common conductor 96 and voltage divider resistance R98 to power supply terminal 300V is completed. The flow of current through this circuit results in a lowering of the positive voltage across the voltage divider resistance R99, and consequent reduction in the positive control grid bias on tubes 124 and 126, which causes plate current to start to flow through said amplifier tubes.

The energization of the relay 92 causes closure of the relay switch 92b, thus connecting the bus 82 to ground and thereby tuning the oscillator 10 to the frequency determined by the previously mentioned condensers, which are thus effectively in the grid tuning circuit of the oscillator tube 30. This grounding of the conductor 92 also results in changing the ground point of the series of biasing resistors RC# to RB, and thus lowers the biasing potential on the conductor 54 to a value sufficiently more negative to condition the relaxation oscillators 12 to 17 to follow safely the change in frequency of oscillator 10.

It will be understood that the grid bias on the relaxation oscillator tubes 38 is an important factor in determining the rate of relaxation, and that it is necessary to change the rate of relaxation of each of the oscillators 12 to 17 through a range of substantially an octave. Changing the grid bias on the tubes 38 of the relaxation oscillators affords a simple method of simultaneously changing the frequency range through which the relaxation oscillators 13 to 17 may be effective. The exact frequency at which the oscillators 12 to 17 will operate is determined by the amplitude and frequencies of the signals impressed upon the grids of their tubes. The condenser C4 may be of relatively low value (e. g. .003 mfd.), thereby to limit the amplitude of the signal impressed upon the grid of the tube 38 forming part of oscillator 12, and to impart a desirable sharply peaked wave shape to this signal, to improve the stabilization of the oscillator 12.

Since the oscillator 12 operates at the same frequency as the oscillator 10, the coupling afforded by the condenser C4 is not very critical and in practice need not be made adjustable. The amplitude of the signals impressed upon the grids of the remaining relaxation oscillators 13 to 17 is adjustable during the construction of the instrument, by adjustment of the potentiometers R9 having the movable contacts 52. In practice, this adjustment is made such that equal increments of bias may be added and subtracted from that impressed upon the conductor 54 without causing loss of the frequency stabilization control, thus conditioning the relaxation oscillator for the greatest safety as regards following the frequency changes of the preceding oscillator, and maintaining exact frequency division by the factor 2. For example, a small variable bias battery of 1½ volts may be connected in the conductor 54 adjacent the voltage divider R12 and R13, and said battery alternately inserted with its potential such as to add or subtract from the potential provided by the voltage divider system previously described. If all of the relaxation oscillators 12 to 17 continue to operate when the bias on the conductor 54 is thus changed through a range of 3 volts, the oscil-

lators may be considered to be operating safely. If any of the oscillators 12 to 17 fail to divide properly under the conditions where the voltage on the conductor 54 is changed through this range of 3 volts, adjustment of the associated potentiometer R9 and R52 is made until such condition does obtain.

Thus, upon closure of the relay switch 92b, oscillator 10 will be tuned to the note G of the highest octave (3136 c. p. s.), and the oscillator 12 will likewise follow this frequency while the oscillators 13 to 17 inclusive will oscillate at frequencies of 1568, 784, 392, 196 and 98 c. p. s. respectively. Assuming that register control 105 has been operated, signals from the oscillators 15, 14 and 13 will be impressed upon the conductors 101, 102 and 103 respectively. Thus, when the relay 92 is operated and the relay switch 92c closed, the signal from the oscillator 14 will be supplied through the conductor 102 to the conductor 100, and hence be impressed upon the grid of the amplifier tube 120 through the condenser C12.

Energization of the relay 92 also opens relay switch 92a, thus opening the current supply circuit for the windings of relays 91 and 93. As a result, assuming that key G2 is held depressed, further depression of a single key in either of the adjoining octave groups of keys C1 to B1, or C3 to B3 will have no effect. Depression of an additional key of the group C2 to B2 may, however, have a tuning effect if the second depressed key is such as to lower the frequency of oscillator 10.

It is of course contemplated that the player shall never press more than two keys at one time. If, for example, while holding the key G2 depressed the player should depress the keys C3 and C#3, the condensers CC3 and Cc3 as well as the resistor RC3 would be shunted through the bus 93 and thus would alter the tuning of the oscillator 10.

Closure of relay switches 92b and 92c causes the signal of the proper frequency to be impressed on the grid of the amplifier tube 120. Also, the amplification of tubes 124 and 126 is rising because of the change in potential of conductor 96 at a desired rate of attack. Inasmuch as contacts 92b and 92c are made relatively soon after the voltage is applied to relay winding 92, the amplification of tubes 124 and 126 will not have reached a substantially high value at the time that closure of said relay contacts occurs.

If, however, the relays operate relatively slowly, the potential on the conductor 96 and hence on the cathodes of the tubes 124, 126, may be of such low value, when none of the relays is energized (by proper selection of the values of the resistors R98 and R99), so that the tubes 124, 126 are normally biased considerably beyond cutoff. Thus, upon energization of any of the relays 91, 92, 93, a certain length of time will be required for the potential on the cathodes of the tubes 124, 126 to build up to the cutoff potential due to the time delay afforded by the condenser C14 and resistor R16. This time delay may be correlated with the speed of operation of the relay armatures so that a condition cannot arise that the amplifier tubes 124 and 126 have appreciable gain before the relay switches 91c, 92c or 93c, as well as the tuning relay switches 91b, 92b or 93b, have operated to complete their respective circuits. Thus, any transients incidental to the closure of said contacts

do not appear as noticeable sound from the speaker 146.

When playing key G2 is released, contact G2b is first broken by said playing key, thus de-energizing relay 92 and causing the potential on conductor 96 to rise to cutoff value for tubes 124 and 126. This rate of decay of operating bias on tubes 124 and 126 is controlled by condenser C10 and resistance R99 and is of such value as to provide a click-less decay rate. Thus, the amplifier begins to decay immediately upon the opening of contact G2b. Following this operation and at a time when the amplifier is substantially cut off, the contacts 92a, 92b and 92c associated with relay 92 are operated. In this way, all transients due to changing the tuning of the generator system and keying of the signals supplied by said generating system are eliminated, thus making the attack and decay musically acceptable.

When the player plays a note such as the note G2 with the results just described, and while holding this key depresses another key, such as, for example, the key C3 in the higher octave of keys, the depression of the key C3 does not have any effect until the key G2 is released.

The relay contacts are preferably so arranged that upon energization of the associated relay, the contacts 91a, 92a and 93a are opened after the make contacts have been made, and may preferably take place as near as possible to the end of the relay armature movement. Similarly, upon de-energization of the associated relay, its contact 91a, 92a or 93a will complete the circuit after the other relay switches have opened. By reason of this sequence of operation of the relay switches, the shift of the tone from the note G2 to note C3 takes place in a minimum interval of time because relay 93 is energized very shortly after relay 92 is de-energized upon release of the key G2. As a result, relay switches 92b and 92c open substantially simultaneously with the closure of relay switches 93b and 93c. There must be a slight interval between these operations in order to provide time for the change in bias on the push-pull tubes 124, 126 through the conductor 96, and the amplifier is substantially cut off during this interim of time. The relays 91, 92 and 93 may be ordinary telephone type relays, but are preferably provided with platinum or some other precious metal contacts.

For example, if the player, while still holding the key G2 depressed, depresses another key in the same octave—for example key A2—the relay 92 is not de-energized and upon release of the key G2, the oscillator 10 will have its frequency shifted to the new frequency substantially instantaneously upon release of the key G2. On the other hand, if, while holding the key G2 depressed, he presses a lower note in the same octave—for example the note D2—the frequency of the oscillator 10 will immediately be shifted to the new frequency of the note D even before the key G2 is released.

It is intended that the instrument be used to play melodies and as such, it is seldom, if ever, that two succeeding notes will lie one in the lowermost octave and one in the highest octave of the keyboard. However, should the player simultaneously depress keys in the lowest and highest octaves, such for example as the keys D1 and G3, both relays 91 and 93 will be energized. The oscillator 10 will, however, be tuned to the note of lowest designation, namely, the note D1. Two signals will appear on conductor 100 which will

be associated with the signal contacts of each of the two relays 91 and 93. Thus, the D note will sound as a low D note and another D note two octaves higher. As a result of depressing these two keys, the voltage on conductor 96 will be more negative than ordinarily (because of the lowered impedance of the two windings of the relays 91 and 93 in parallel), and as a result, tubes 124 and 126 will be overly biased, which will cause them to introduce harmonic distortion into the signal, which distortion products, however, will be harmonics of the lowest of the two D signals. Under these conditions, the tones heard will be very loud, and produce a very bizarre effect which will ordinarily not be desired, but may be utilized upon rare occasions.

During the playing of the instrument, the swell or volume control may be operated at will successively to connect or disconnect the resistors R20 to R24 in parallel, thus changing the grid bias on the tubes 124 and 126, which results in a change in the amplification factor of these remote cutoff tubes 124 and 126. Since the change in grid bias effected by the volume control is made gradual by virtue of the condenser C15 and resistor R17, the changes in the volume of the output are correspondingly gradual. Furthermore, any odd harmonic distortion introduced by the curvature of the grid characteristics of the remote cutoff tubes 124 and 126 tends to be substantially eliminated due to the push-pull arrangement utilized.

Whenever the player desires to change the register in which the tone sounds, he may operate the desired register controls 104 to 107 and thus shift the tonal register of the three octaves of keys provided. If desired, two or more of these register controls 104 to 107 may be operated simultaneously, thus providing an effect similar to that obtained by the use of coupler switches in pipe organs, or that of more than one instrument playing simultaneously in octave or multi-octave relationship. These register controls when two or more are used simultaneously, may be thought of as effecting changes in the tone quality. It will be understood that the register controls may be of the type, such as pipe organ stop tablets, which remain in either of their two positions to which they are moved.

The resistors R104a to R107a, R104b to R107b, and R104c to R107c may be of different values so as to provide means whereby the compounding of tones produced through simultaneously using a plurality of register controls may be varied such that the octave coupling may be more or less than that which one would expect were it possible to play an octave on the keyboard.

It will be understood of course that resistors R104a, R104b and R104c must be of such value as to match in intensity the lowest note of one octave group to the highest note in the adjoining octave group. However, resistors R104a and R105a, for example, may be chosen on the basis of voicing and musical judgment. Of course resistors R104a to R107a should not vary materially as the level of the tones associated with each of the register controls 104 to 107 should be approximately the same, to make full use of the amount of amplification provided with each of the register controls.

Power supply system

In the previous description of the instrument, various terminals have been referred to from which voltages and values represented by the

reference characters of the terminals are supplied. Any suitable power supply capable of providing these voltages with reasonably good regulation may be used. In Figure 2, we have, however, shown a particular form of power supply system which is well adapted for this purpose. It comprises generally an input power transformer 160 having a primary 161 which is supplied with 115 volt alternating current, being controlled by an on and off switch 162. The secondary winding 163 of the transformer 160 has its terminals connected to the plates of a full wave rectifier tube 164 of a suitable type such as the 5U4G tube, the filament of which is supplied with current by a tertiary winding 166. The heaters of the various tubes of the instrument are supplied by an additional secondary winding 168, the center tap of which is connected to terminal 10V.

The center tap of the winding 163 is impressed upon an input filter system comprising condensers C24 and C26, and an inductance L14 which may be the field winding of the speaker 146. A protective resistance R40 is connected between the filament of tube 164 and the condensers C24 and C26, which are connected to the positive output conductor 170, and the negative output conductor 172 which is connected to ground. A voltage divider resistance R41 is connected across conductors 170 and 172.

Terminals 50V and 150V are connected to suitable taps on the voltage divider resistance R41, while the terminal 300V is directly connected to the conductor 170. The terminals 50V, 150V and 300V are connected as previously described, to supply power for the amplifier 26. It is to be expected upon closure of one of the playing keys, that the current drawn by the amplifier will change because of the changing load. This change in load will reflect itself as a change in voltage between the conductors 170 and 172.

Relaxation oscillators 12 to 17 will relax at substantially the same frequency provided that the ratio at their grid bias and plate bias remains constant. In order that the relaxation oscillators 12 to 17 will have the ratio between their plate voltage and grid bias constant, a separate voltage divider R42 is provided for the relaxation oscillators, being tapped at point 176, connected to terminal 10V, which serves as a source of cathode potential for the tubes 38. A condenser C28 is connected between the tap 176 and the conductor 172 serving as a filter for the potential between the tap 176 and the conductor 172. Bias for the amplifier tube 120 is obtained from a terminal 2V, being provided by divider resistance R44, tapped at its mid-point, and filtered by resistor R46 and condenser C30.

The terminal 250V is connected to the conductor 170 through a filter resistor R48, and a filter condenser C32 connects the terminal 250V to ground. The terminal 250V is utilized to supply the plate current and voltage for tube 120. The terminal 280V is connected to the conductor 170 through a filtering resistor R50, and is connected to ground through a filtering condenser C34. The terminal 280V is the source for plate voltage for the tubes 38 of the relaxation oscillator circuits.

The terminal 100V is connected to the conductor 170 through a filtering resistance R52 and connected to ground through a filtering condenser C36, the terminal 100V being utilized to supply current to the vibrato mechanism for the vibration of the reed thereof.

General operation

Upon closure of the on and off switch 162, the instrument will, as soon as the tubes have become heated, be conditioned for playing. The oscillator 10 will, provided no keys are depressed, commence oscillation at the frequency of the note B in the highest octave range, namely, at 3951 c. p. s., and the controlled oscillators 12 to 17 inclusive will of course oscillate at corresponding octave frequencies below that of the oscillator 10.

As previously noted, the inductance 34 is variable. This inductance may be adjusted preferably by changing the size of the air gap in the core of the transformer. Such tuning will ordinarily be unnecessary since the oscillator 10 is of very stable construction and has excellent frequency stability, but it may be necessary when it is desired to tune the instrument to the pitch of some other instrument which cannot be readily tuned.

The player may then select the register in which he wishes to play, by operating one or more of the register selectors 104 to 107. Thus, signals from oscillators selected from the group 12 to 17 will be impressed selectively upon the conductors 101, 102 and 103, which lead to the relay operated switches 91c, 92c, and 93c respectively.

After making a suitable selection of the resonant filter circuits to be employed, by opening one or more of the switches 150 to 155, the instrument will be ready for use. When closing the on and off switch 162, the player will either independently or incidental to the operation of said switch, flick the vibrato reed 58 to cause it to commence vibrating. Thereafter the reed will automatically continue its vibration. Before playing, the operator, if he desires the vibrato tone, will operate either one or both of the switches 70 and 72 to cause the desired vibrato frequency shift in the frequency of oscillation of the oscillator 10. Likewise, if a slow attack of the tone is preferred for the particular selection to be rendered, the musician will close the switch 132.

Having thus set the various controls, the instrument is in condition for playing, and is played as a melody instrument usually with an organlike, legato touch.

As previously mentioned, any suitable frequency generating system using any one of various types of oscillators may be employed in the instrument in place of the frequency generating system disclosed herein. The frequency generating system per se does not form a part of our invention claimed herein, except in combination with the remaining parts of the instrument.

Our invention has been described as relating to a "melody instrument," by which we mean an instrument in which ordinarily but one note is sounded at one time so that it is not generally capable of playing chords. The instrument disclosed herein is thus primarily a melody instrument as thus defined, although, as previously stated, chords consisting of notes in octave relationship may be played upon the instrument. Furthermore, by the use of several manuals and duplication of other parts of the instrument, it will be readily apparent that an instrument capable of playing chords could readily be constructed. It is with these facts in mind that the instrument is generally described herein as a "melody instrument."

While in a number of instances various elements of the circuit have been specified as being of particular values, these values may, as is well known in the art, be varied considerably, especially if compensatory changes are made in the arrangement or values of other parts of the instrument. It will be apparent to those skilled in the art that numerous variations, modifications and alterations may be made in the instrument without departing from the underlying principles thereof. We therefore desire, by the following claims, to include within the scope of our invention all such modified constructions whereby substantially the results of our invention may be obtained by substantially the same or equivalent means.

We claim:

1. In an electrical musical instrument, the combination of a plurality of groups of keys, a relay associated with each group of keys, circuits for energizing each of said relays upon depression of any of the keys of its associated group, and means operated upon energization of any one of said relays to open the energizing circuits of relays associated with the groups of keys located immediately adjacent the group of keys associated with the energized relay.

2. In an electrical musical instrument, the combination of three groups of keys, a relay associated with each group of keys, circuits for energizing said relays respectively upon depression of any key in the group associated with the relay to be energized, and means operated by the energized relay for preventing the energization of the relay associated with each group of keys located adjacent the group of keys associated with the energized relay.

3. In an electrical musical instrument, the combination of three groups of keys, three relays associated respectively with said groups of keys, a relay energizing circuit for each of said relays, switches operated by the keys of each group for completing the circuit for energization of the relay associated such group, normally closed switch contacts operated by said relays respectively, said normally closed switch contacts of one relay being in at least one of said circuits for energizing another of said relays.

4. In an electrical musical instrument, the combination of three octaves of keys, a relay associated with each octave of keys, switch contacts associated with each relay and opened upon energization thereof, and an energizing circuit for each of said relays arranged to be completed upon depression of any one of the keys of the octave associated therewith, each of said circuits including at least one of said switch contacts of one of the other relays.

5. In an electrical musical instrument, the combination of a plurality of keys divided into groups, a relay associated with each group of keys, circuits for energizing said relays upon depression of any key of the group associated with the particular relay to be energized, switch contacts opened upon energization of said relays respectively, and circuits connecting the switch contacts of the relay associated with one group of keys in the relay energizing circuits for relays associated with adjacent groups of keys, whereby upon energization of a relay associated with one group of keys the depression of a key in an adjacent group will be ineffective to energize the relay associated with such adjacent group.

6. In an electrical musical instrument of the melody type, the combination of a plurality of

5 octave groups of keys for controlling the transmission to the output of the instrument of signals from sources supplying signals of musical frequency, a relay for each octave group of keys, an energizing circuit for each of said relays arranged to be rendered effective upon operation of any of the keys in its associated octave group of keys, and means operated by each of said relays upon the energization thereof to prevent the energization of a relay associated with an adjacent octave group of keys.

10 7. In an electrical musical instrument having a plurality of inter-stabilized electrical impulse generators providing impulses at frequencies bearing octave relationship with respect to one another, and having an electron discharge tube amplifier and electroacoustic translating means supplied with the output of said amplifier, the combination of a plurality of manually depressible keys, a pair of switches operable sequentially by each of said keys, a relay, an energizing circuit for said relay including one of said key-operated switches, means responsive solely to current flow through said relay energizing circuit to cause a controlled rate of change in the amplification by said electron discharge device, and a switch operated by said relay to connect one of said sources to the input circuit of said electron discharge device.

15 8. In an electrical musical instrument of the melody type having a plurality of manually operable keys, tunable sources of electrical impulses of different musical frequencies, and having an amplifier and loud speaker; the combination of a switch operated by each of said keys and effective to condition said sources to be tuned to frequencies correlated with the nominal frequency corresponding to the note of the key depressed, a relay having an energizing circuit and a pair of contact switches which are closed upon energization of the relay, an energizing circuit for said relay including a second switch operated by said key, means controlled by one of said relay contact switches to conduct a signal from one of said sources to said amplifier, a circuit controlled by the other of said contact switches for rendering effective the tuning of said sources, and means rendered effective by current flow through the energizing circuit of said relay to change the gain of said amplifier.

20 9. In an electrical musical instrument having a plurality of electrical impulse generators providing impulses at frequencies bearing octave relationship with respect to one another, and having an electron discharge tube amplifier and electroacoustic translating means supplied with the output of said amplifier, the combination of a manually depressible key, a switch operable by said key, a relay, an energizing circuit for said relay including said key-operated switch, means responsive to current flow through the energizing circuit of said relay to cause a rise in the gain of said electron discharge device tube amplifier, and a switch operated by said relay to connect one of said generators to the input circuit of said electron discharge tube amplifier.

25 10. In an electrical musical instrument, the combination of a plurality of groups of keys, a relay associated with each group of keys, circuits controlled by said keys of each group for energizing the relay associated therewith, and means operated by each relay upon the energization thereof to open such of said circuits as energize the relays associated with adjacent groups of keys.

30 11. In an electrical musical instrument having an electron discharge tube amplifier and electroacoustic translating means, the combination of a plurality of generators of electrical impulses of harmonically related frequencies, means to tune said generators to frequencies of harmonically related notes of the musical scale, a plurality of groups of keys, a switch operated by each of said keys respectively to condition said tuning means to tune said generators to predetermined frequencies, a relay having a winding and a pair of contact switches closed upon energization of said winding, a circuit including one of said contact switches for rendering effective said tuning means, a circuit completed by said second contact switch to supply electrical impulses from one of said generators to said amplifier, means normally effective to bias an electron discharge tube of said amplifier beyond cutoff, means to complete an energizing circuit through the winding of said relay upon depression of any one of the keys of one of said groups, and means for changing the bias on said tube at a controlled rate as a result of current flow through the winding of said relay.

35 12. In an electrical musical instrument having an output amplifier including a multi-electrode electron discharge device, a voltage divider circuit normally supplying a potential to said device sufficient to bias said device substantially to cutoff, a relay controlling the transmission of a signal to said amplifier, and a key controlled energizing circuit for said relay, said circuit being in parallel with a portion of said voltage divider circuit, the impedance of said energizing circuit being of such value with respect to the impedance of said portion of said voltage divider circuit that the bias on said electron discharge device will be reduced to a value above cutoff whenever said energizing circuit is completed.

40 13. In an electrical musical instrument of the melody type having a multi-octave range keyboard, a plurality of electron discharge device generators of musical signals bearing octave frequency relationship to one another, means controlled by keys of corresponding note designation of different octaves simultaneously to tune all of said generators to frequencies corresponding to such note designation, an amplifying electron discharge device, means normally biasing said device substantially to cutoff, a relay having an energizing circuit closed by depression of any of the keys of an octave of said keyboard, means affected by current flow through said circuit for decreasing the bias on said device at a predetermined rate, and a circuit completed upon energization of said relay to impress a signal from one of said generators upon said amplifying device.

45 14. In an electrical musical instrument having a plurality of octave groups of keys, a plurality of generators, an amplifier, a plurality of circuits controlled by said keys for connecting said generators to said amplifier, and means operated upon completion of one of said circuits under the control of a key of one of said groups to prevent the completion of another of said circuits under the control of a key in an adjacent group.

50 15. In an electrical musical instrument, an amplifier including an electron discharge device having a cathode, plate and control grid, a voltage divider determining the operating potential of said cathode, a relay, a circuit controlled by said relay for impressing a musical signal upon

the grid and cathode of said device, and a key-controlled circuit for energizing said relay, said key-controlled circuit being in parallel with a portion of said voltage divider, whereby the potential of said cathode is changed upon completion of said key-controlled circuit.

16. In an electrical musical instrument having means for generating and controlling a musical signal and having an amplifier including a multi-electrode electron discharge device for receiving a signal from said generating and controlling means and transmitting the signal to electroacoustic translating means; means to control the amplitude of the signal output of said device comprising, a terminal, a source of direct current potential adjustable by relatively few and large increments, said adjustable source being connected to said terminal, means readily operable by the player of the instrument for adjusting the potential of said source, a reactive element connected between said terminal and a point of fixed potential, said element being of sufficient reactance to cause the rate of change of potential on said terminal to change smoothly despite abrupt changes in the potential of said source, and means connecting said terminal to one of the electrodes of said device to determine the bias thereof.

17. In an electrical musical instrument having means for generating and controlling a musical signal, an amplifier including a variable- μ vacuum tube for receiving said signal and transmitting it to electroacoustic translating means; means to control the amplitude of the signal output of said tube comprising, a terminal connected to the control grid of said tube, a voltage divider having a connection to said terminal for determining the potential thereof, said voltage divider being adjustable only by relatively large steps, means readily operable by the player of the instrument for controlling the adjustment of said voltage divider, and a reactive element connected between said terminal and a point of fixed potential, said reactive element being of sufficient value to cause the potential on said terminal to change gradually from one potential value to another upon abrupt adjustment of said voltage divider from one position of adjustment to another.

18. In an electrical musical instrument, the combination of an oscillator having an adjustable tuning circuit including a plurality of condensers connected in series, voltage dropping resistors connected in parallel with said condensers respectively, key operated switch controlled circuits for selectively shunting groups of said condensers, and a plurality of inductances of relatively low impedance connected in series with said condensers between groups thereof, whereby the discharge of condensers shunted by said key controlled circuits will be impeded to reduce arcing upon opening and closing said key operated switch controlled circuits.

19. The combination set forth in claim 18 in which two of said inductances are provided and

in which said inductances are mutually coupled.

20. In an electrical musical instrument, the combination of a signal generating oscillator, the frequency of oscillation of which is determined by an adjustable reactance, a plurality of keys, a plurality of circuits for adjusting the reactance of said adjustable reactance, a pair of switches in each of said circuits, means for closing one of said switches in each of said circuits upon depression of one of said keys respectively, a second switch operated by each of said keys, and a relay energized upon closure of said second key operated switch, said relay being effective to close the other switch of said pair of switches.

21. In an electrical musical instrument having means for generating and controlling a musical signal, and an amplifier including an electron discharge device for receiving said signal and transmitting it to an electroacoustic translating means; means to control the amplitude of the signal output of said device comprising, an element readily operable by the player of the instrument, a plurality of fixed impedances forming part of a voltage controlling circuit and arranged to be successively connected in the circuit by said element, a terminal the potential of which is determined by the number of said impedances which are connected in said circuit, a reactive element connected between said terminal and a point of fixed potential to limit the rate of change of potential on said terminal, and means connecting said terminal to one of the electrodes of said electron discharge device to determine the bias thereof.

22. In an electrical musical instrument having an oscillator the frequency of oscillation of which is determined in part by the amount of inductance in a tuning circuit thereof, the combination of a coil having end terminals and intermediate taps, said coil forming the tuning inductance of the oscillator, a pair of inductance elements normally connected in parallel across said intermediate taps, a periodically operating interrupting switch having one contact thereof connected to one of said terminals, and manually operated switches separately operable to disconnect a terminal of each of said inductance elements respectively from an intermediate tap of said coil and connect it to the other contact of said interrupting switch.

23. In an electrical musical instrument having an oscillator the frequency of oscillation of which is determined in part by the amount of inductance in a tuning circuit thereof, the combination of a coil having end terminals and intermediate taps, said coil forming the tuning inductance of the oscillator, a pair of inductance elements normally connected in parallel across said intermediate taps, and means selectively rendered effective to connect either one or both of said inductance elements periodically in parallel with the portion of said coil between one terminal thereof and the tap thereof nearest said terminal.

LAURENS HAMMOND.
JOHN M. HANERT.